

DK790-XEC

4½ DIGIT LOOP LCD DPM INSTALLATION SHEET

PANEL CUTOUT & DIMENSIONS

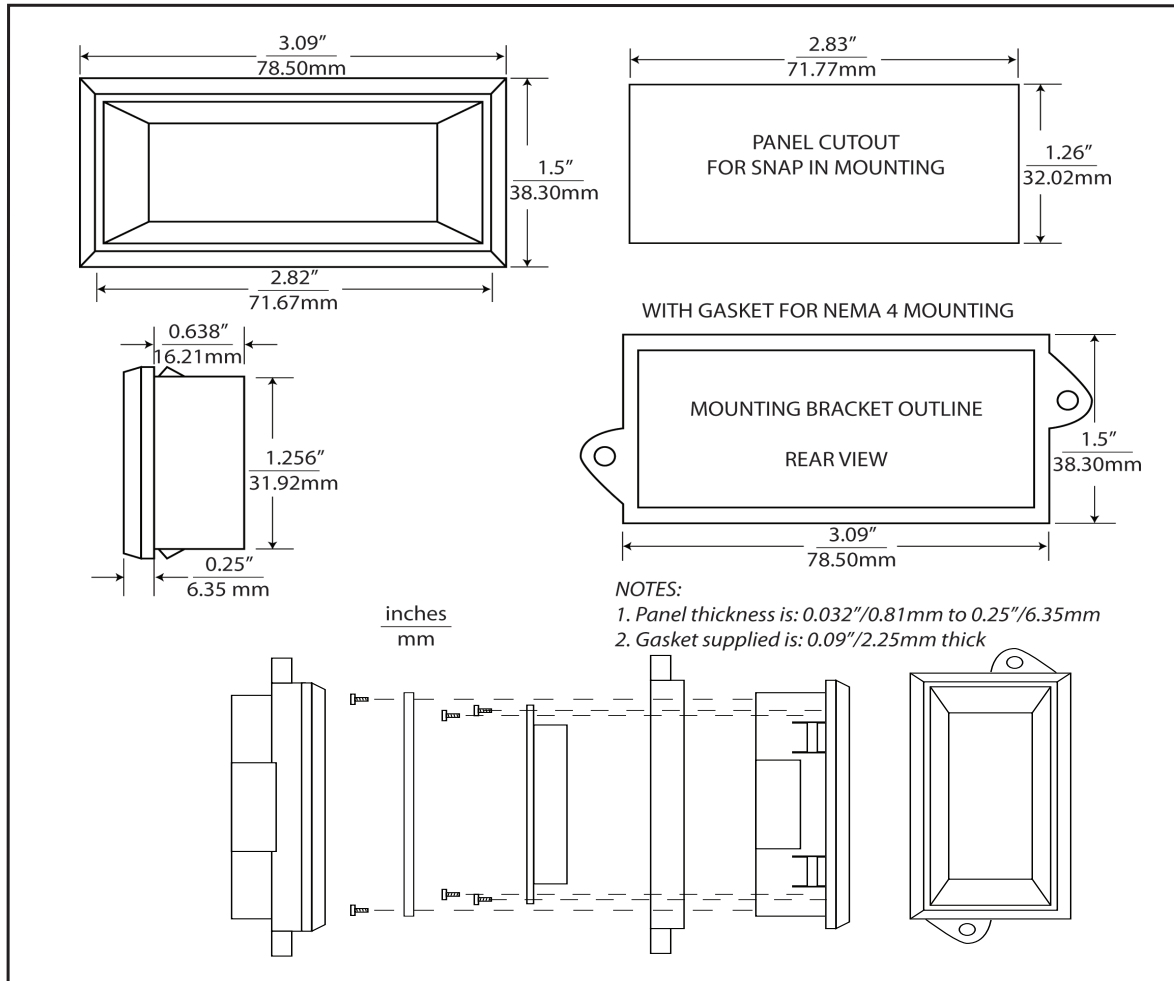

JUMPER SELECTION AND WIRING

1. DECIMAL SELECTION

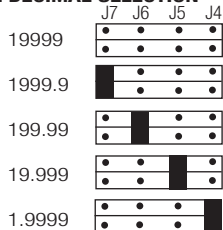

2. J1, J2, J3 SELECTION

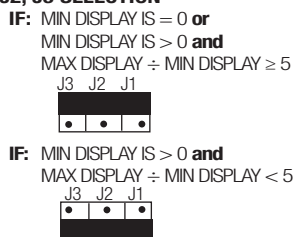

3. SPAN JUMPER SECTION:

SPAN FACTOR	SET JUMPERS
0-12	L
10-22	M
22-32	H

IF: MIN DISPLAY IS ≤ 0 **or**
 MIN DISPLAY IS > 0 **and** MAX DISPLAY ÷ MIN DISPLAY > 5
THEN: SPAN FACTOR = $\frac{2.5 (\text{MAX DISPLAY} - \text{MIN DISPLAY})}{4000 + 0.02 (\text{MIN DISPLAY}) - 0.004 (\text{MAX DISPLAY})}$

IF: MIN DISPLAY IS > 0 **and** MAX DISPLAY ÷ MIN DISPLAY ≤ 5
THEN: SPAN FACTOR = $\frac{\text{MAX DISPLAY} - \text{MIN DISPLAY}}{1600}$

4. ZERO (OFFSET) JUMPER SELECTION:

ZERO FACTOR	SET JUMPERS
0-3994	H
3320-7314	M
6640-10634	L

IF: MIN DISPLAY IS ≤ 0 **or**
 MIN DISPLAY IS > 0 **and** MAX DISPLAY ÷ MIN DISPLAY > 5
THEN: ZERO FACTOR = $\frac{(250000 + \text{MIN DISPLAY})}{(250000 + 400 (\text{SPAN FACTOR}))} \times (83834) - 73200$

IF: MIN DISPLAY IS > 0 **and** MAX DISPLAY ÷ MIN DISPLAY ≤ 5
THEN: ZERO FACTOR = $10634 - (\text{MIN DISPLAY} - 400 (\text{SPAN FACTOR})) \times 83834$
 250000

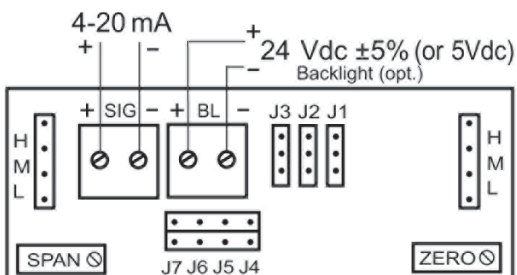

WIRING

